

Order no.: REF-30208732

Platform with step ladder



Specification

Business division MUNK Günzburger Steigtechnik	Sector Industrial systems	Type mobile	Height fixed
--	-------------------------------------	-----------------------	------------------------

Facts

- Decking: Grooved aluminium
- Total height (H): 2,523 mm
- Platform length (PFL): 850 mm
- Platform width (PFB): 850 mm
- Platform height (PFH) top edge: 1,408 mm
- Stepladder SB: 600 mm
- Clear width of safety door: 660 mm
- Projection (stepladder retracted): approx. 1,161 mm
- Total load: 200 kg
- Step load: 150 kg

Description

Client's Request and Task

In the modern industry, where safety and ergonomics at the workplace are of utmost priority, our goal was to create a product solution that meets our client's requirements for safe and ergonomic access to maintenance areas on machines. The challenge was to design a platform that not only increases efficiency and safety during maintenance work but is also absolutely compliant with standards and comfortable for the employees to operate.

Customer requirements

- Enhancing safety during maintenance work on industrial machines
- Enabling ergonomic and safe working conditions for the staff

- Development of a stable, reliable, and standards-compliant work platform

Our Solution

Platform with Integrated Ladder

We present a platform with an innovatively designed step ladder that is extendable and securely lockable, providing users with a flexible and stable access solution.

Flexible and Safe

The step ladder can be adjusted in a precisely manufactured guide rail and securely fixed with locking pins in both working and resting positions. In the extended state, it also serves as a support structure, thereby increasing safety.

Precise Connection

A carefully designed connection to the client's machine ensures smooth integration. The guide rail, equipped with an internal guide carriage, allows the platform to be moved approximately 640 mm to the left and right.

Locking and Support Wheels

The platform is locked using a practical spring bolt. Two robust support wheels under the platform ensure stability and easy maneuverability.

Comprehensive Protection

A permanently installed railing with a diameter of 50 mm, equipped with foot and knee ledges, provides additional protection. Access to the platform is enhanced by a safety door (SI door), ensuring safe entry and exit.

Technical Specifications

The platform, with its ribbed aluminum surface, provides optimal footing, a total height of 2523 mm, and a platform size of 850 mm in both length and width. The working height of the platform is 1408 mm above the ground. The step ladder has a width of 600 mm, and the safety

door a clear width of 660 mm. In the retracted state, the step ladder protrudes approximately 1161 mm. The platform can bear a total load of 200 kg, while each step is designed for a load of up to 150 kg.

Conclusion

This custom-designed platform with step ladder stands as our commitment to revolutionizing occupational safety and ergonomics in the industrial sector. It embodies an intelligent combination of functionality and safety, surpassing all expectations of a standards-compliant work environment. Our solution enables employees to work efficiently, comfortably, and most importantly, safely, setting a new standard in the industry.

Information on sustainability criteria

- Corporate certification: ISO 9001
- Corporate certification: EN 1090
- Corporate certification: EcoVadis
- RoHS
- REACH
- The MUNK Group complies with a Code of Conduct
- The Supply Chain Act does not apply due to our size
- The materials used are listed in the technical specification
- Resource-saving production: own photovoltaic systems
- Energy-efficient consumption during production: LED lighting
- Repairability, durability and quality: 15-year warranty on series products made in Germany
- Recyclability: Our products are mostly made of aluminium, steel or wood and can be fed directly into the recycling process.
- Socially acceptable working conditions in production: fair wages, gender equality
- Economical and recyclable packaging: no use of polystyrene, predominantly use of wood and cardboard, small amounts of plastic
- No health hazards for the users

More product pictures

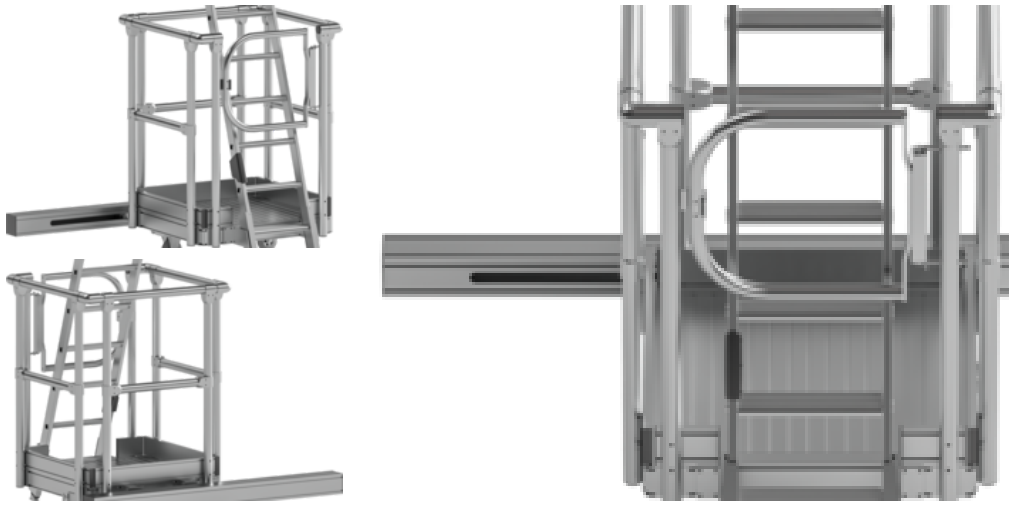

Added value

Trust us as your competent partner for tailored access equipment solutions. From analysis and design to construction and premium after-sales service, we are the industry leader.

★ Analysis

We set the benchmark when it comes to evaluating access equipment requirements. Our experts take the time to fully understand your specific needs. Following a thorough analysis, we present a customised solution precisely tailored to your individual circumstances. Rely on us to identify your challenges and provide innovative solutions.

★ Design

We lead the way in planning bespoke solutions. With creativity, technical expertise, and a deep understanding of access equipment, we develop groundbreaking concepts. Our experienced team designs outstanding solutions that meet the highest safety standards while maximising efficiency and ergonomics for you. Let our expertise and innovative strength impress you.

★ Construction

In construction, we set the bar high. Our engineers and production planners possess unique expertise and extensive experience in access equipment. Using state-of-the-art technologies and high-quality materials, we realise your design down to the smallest detail. Precision and quality are our top priorities, ensuring bespoke solutions that meet the highest demands.

★ Production

At our modern production facilities in Günzburg, we professionally and efficiently bring your plans and requests to life. Our specialists in access equipment, electronics, and mechanics focus on one thing: quality that delivers on its promises. Every construction, big or small, is crafted with the utmost care and precision and rigorously tested before shipping.

From decades of experience, we know that individual requirements require special solutions. That's why we are here to help you realize your custom construction.

Get inspired by our reference products and make your unique idea a success. We look forward to supporting your project with our expertise and dedication. Contact our competent team for more information and assistance.

With MUNK Group by your side, your custom construction becomes a reality: Safety. Made in Germany.

What we offer

- On-site consultation and project planning
- Custom development according to your requirements
- Precision manufacturing
- Functional and cost-effective access solutions
- Maximum workplace safety
- Fast delivery
- Compliance with all relevant German, English, and international standards and regulations, such as BetrSichV, DGUV regulations, Machinery Directive 2006/42/EC

[OPEN CONTACT FORM](#)



★ **After Sales**

Our commitment doesn't end with the completion of your bespoke solution. We excel in after-sales service. Through assembly, maintenance, inspections, and repairs, we ensure your customised access equipment remains in perfect condition. Our reliable team offers top-tier customer service, ensuring your satisfaction is always our priority.



Corporate certifications

on sustainability criteria



Management System
ISO 9001:2015
ISO 14001:2015
www.tuv.com
ID 9108612548

