

Order no.: REF-30215309-2

## Assembly carriage with central locking

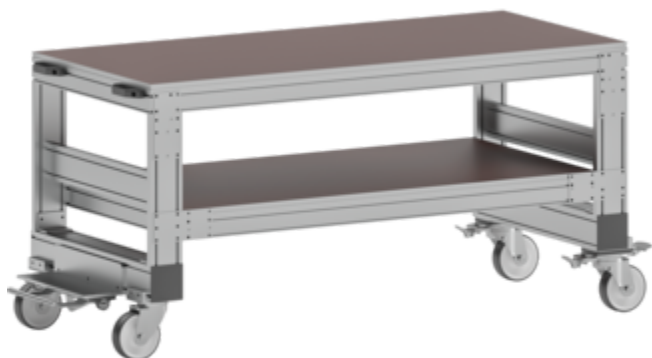

### Specification

Business division <b>MUNK Günzburger Steigtechnik</b>	Sector <b>Transport logistics</b>	Type <b>mobile</b>	Height <b>fixed</b>
--	--------------------------------------	-----------------------	------------------------

### Facts

- Platform width (PFB): 800 mm
- Platform length (PFL): 1,800 mm
- Top edge of platform 1: (PFH1) 900 mm
- Top edge of platform 2: (PFH2) 484 mm
- Platform covering: Wood screen printing
- Chassis: ZBS 2-2
- 2 swivel castors (Ø 160 mm) operated by foot control lever
- 2 swivel castors (Ø 160 mm) with directional lock
- Foot control lever in the centre
- Total load: 500 kg

### Description

#### Client's Request and Task

In the demanding environment of rolling door assembly for truck bodies, a specialized assembly trolley was required that not only enables ergonomic and safe working for employees but is also stable, reliable, and standard-compliant. A key feature should be the central locking system to optimize the handling and mobility of the trolley.

#### Customer Requirements

- Assembly trolley with central locking for rolling door assembly for truck bodies
- Ergonomic and safe working for employees
- Stable, reliable, and standard-compliant construction

## **Our Solution**

### **Construction and Functionality**

The assembly trolley, designed for the specific needs of rolling door assembly for truck bodies, features two storage surfaces and a chassis with a braking system. The lower platform is adjustable by 90 mm, offering flexible application possibilities. Two handles facilitate the transportation of the trolley.

### **Technical Specifications**

The platform of the assembly trolley has a width of 800 mm and a length of 1800 mm. The height of the upper platform is 900 mm, and that of the lower is approximately 480 mm. The decking is made of robust wood screen-print.

### **Chassis and Maneuverability**

The trolley is equipped with two steering casters controlled by a central foot-operated lever, as well as two steering casters with direction locks. With a wheel diameter of 160 mm, it offers high maneuverability and stability.

### **Load Capacities**

The total load capacity of the assembly trolley is 500 kg, highlighting its robustness and versatility.

### **Conclusion**

The assembly carriage with central locking is an ideal solution for the assembly of rolling doors for truck bodies. It combines flexibility and ergonomics with safety and reliability, thus meeting all the requirements of the demanding assembly environment.

## **Information on sustainability criteria**

---

- Corporate certification: ISO 9001
- Corporate certification: EN 1090
- Corporate certification: EcoVadis
- RoHS

- REACH
- The MUNK Group complies with a Code of Conduct
- The Supply Chain Act does not apply due to our size
- The materials used are listed in the technical specification
- Resource-saving production: own photovoltaic systems
- Energy-efficient consumption during production: LED lighting
- Repairability, durability and quality: 15-year warranty on series products made in Germany
- Recyclability: Our products are mostly made of aluminium, steel or wood and can be fed directly into the recycling process.
- Socially acceptable working conditions in production: fair wages, gender equality
- Economical and recyclable packaging: no use of polystyrene, predominantly use of wood and cardboard, small amounts of plastic
- No health hazards for the users

## More product pictures

---

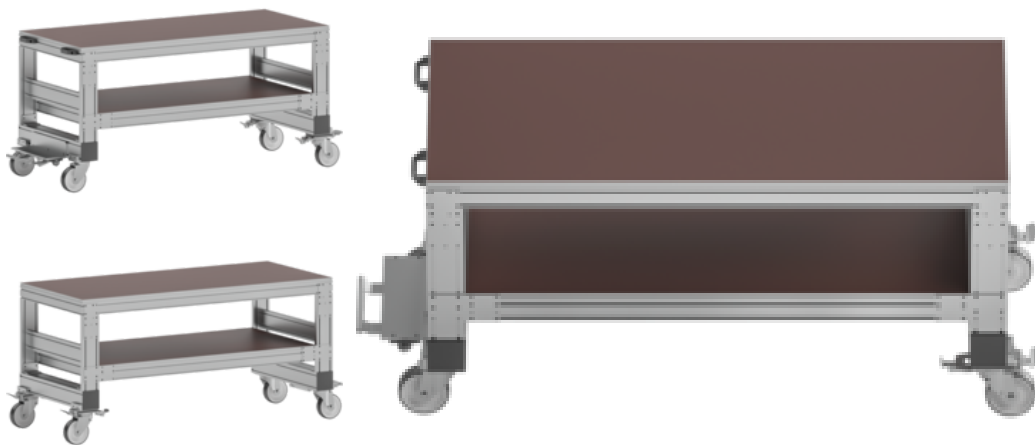

## Added value

---

**Trust us as your competent partner for tailored access equipment solutions. From analysis and design to construction and premium after-sales service, we are the industry leader.**

### ★ Analysis

We set the benchmark when it comes to evaluating access equipment requirements. Our experts take the time to fully understand your specific needs. Following a thorough analysis, we present a customised solution precisely tailored to your individual circumstances. Rely on us to identify your challenges and provide innovative solutions.

### ★ Design

We lead the way in planning bespoke solutions. With creativity, technical expertise, and a deep understanding of access equipment, we develop groundbreaking concepts. Our experienced team designs outstanding solutions that meet the highest safety standards while maximising efficiency and ergonomics for you. Let our expertise and innovative strength impress you.

### ★ Construction

In construction, we set the bar high. Our engineers and production planners possess unique expertise and extensive experience in access equipment. Using state-of-the-art technologies and high-quality materials, we realise your design down to the smallest detail. Precision and quality are our top priorities, ensuring bespoke solutions that meet the highest demands.

### ★ Production

At our modern production facilities in Günzburg, we professionally and efficiently bring your plans and requests to life. Our specialists in access equipment, electronics, and mechanics focus on one thing: quality that delivers on its promises. Every construction, big or small, is crafted with the utmost care and precision and rigorously tested before shipping.

From decades of experience, we know that individual requirements require special solutions. That's why we are here to help you realize your custom construction.

Get inspired by our reference products and make your unique idea a success. We look forward to supporting your project with our expertise and dedication. Contact our competent team for more information and assistance.

With MUNK Group by your side, your custom construction becomes a reality: Safety. Made in Germany.

### What we offer

- On-site consultation and project planning
- Custom development according to your requirements
- Precision manufacturing
- Functional and cost-effective access solutions
- Maximum workplace safety
- Fast delivery
- Compliance with all relevant German, English, and international standards and regulations, such as BetrSichV, DGUV regulations, Machinery Directive 2006/42/EC

[OPEN CONTACT FORM](#)



★ **After Sales**

Our commitment doesn't end with the completion of your bespoke solution. We excel in after-sales service. Through assembly, maintenance, inspections, and repairs, we ensure your customised access equipment remains in perfect condition. Our reliable team offers top-tier customer service, ensuring your satisfaction is always our priority.



## Corporate certifications

---

on sustainability criteria



Management System  
ISO 9001:2015  
ISO 14001:2015  
[www.tuv.com](http://www.tuv.com)  
ID 9108612548

